



# Kick Scooter KQi3

## Service Manual



Jiangsu Niu Electric Technology Co. Ltd



## Contents

<b>Foreword</b>	2
<b>Part Names</b>	6
<b>Scooter Identification</b>	7
<b>Overall specifications</b>	8
<b>Parts Removal and Installation Procedure</b>	11
Preparation	11
forehead body	12
dashboard and dashboard cover	14
headlamp	18
handlebar	21
pedal	28
controller and battery pack	32
rear wheel and rear wheel fender	46
folding parts	50
front fork and front wheel	54
<b>Wiring Diagram</b>	59
<b>Fault Codes</b>	60



## Foreword

Key points in maintenance of Niu KQi3 are described in this maintenance manual.

Preparations in the maintenance manual include notes to all operations. Please read the manual carefully before operating.

Key points in the inspection and adjustment, including maintenance methods for scooter safety and component performance that are applied from regular examinations, are described.

Chapters are edited with disassembly diagrams, system figures and instructions about the maintenance and failure diagnosis.

Note:

Modifications of scooter version or structure as well as photos, pictures or instructions in the manual are referred to physical objects without further notice.

## Maintenance Information

The maintenance and reparation information contained in this manual is for technical specialists only. Maintenance or reparation performed by those who are not trained properly and provided with appropriate tools and equipment may cause injuries to themselves or others and also lead to damages or unsafe conditions of the scooter.

The proper maintenance and reparation procedures, some of which require special tools and equipment, are described in this manual. The risks in terms of personal safety and scooter operation safety, which may be resulted from the use of components, maintenance procedures or tools not recommended by Niu must be verified.

Please make replacement with original electric components made by Niu or equivalents that have corresponding part numbers. We strongly recommend you not to use inferior components.

## Customer Safety Notice

The proper maintenance is crucial for customer safety and scooter reliability. Any errors or omissions in scooter maintenance may result in operating malfunctions, scooter damages or injuries.

Improper maintenance or reparation may lead to unsafe conditions under which serious injuries or even death of your customers or other people may be incurred.

Please carefully follow the procedures and cautions in this manual and other maintenance materials.

## Personal Safety Notice

This manual is used only by professional maintenance technicians, and the warning information about multiple basic workshop safety operation procedures (such as the procedure that requires gloves when working on hot components) is not set forth herein. We recommend you not to carry out procedures specified in this manual without readiness if you have not received the workshop safety training or grasped the knowledge about maintenance safety specifications.

The following are listed as several most importance general notes to maintenance safety. However, we are unable to set forth the warning for each of risks that may arise from maintenance and reparation procedures. You have to determine at your discretion whether a detail task should be implemented.

Failure to properly follow relevant instructions and notes may result in serious injuries or even death.

Please carefully follow procedures and notes in this manual



## Maintenance Rules

1. Metric tools should be made as available as possible in the maintenance of the scooter. Use of improper tools may damage the scooter.
2. Clean off the dirt outside parts or assemblies of the chassis or braking system before guard removal from the scooter or opening for maintenance.
3. Please clean parts and blow them with an air compressor after removal and before measurement of the wearing value.
4. Rubber parts that have become aged or deteriorated are very easy to be damaged by the solvent or oil. They should be checked or replaced if necessary before reassembly.
5. Multiple assemblies should be loosened in the sequence from outside to inside and beginning with small ones.
6. Complex assemblies should be stored in a proper installation sequence for further assembling.
7. Extra attention should be paid to important fitting positions before disassembling. Parts that are no longer to be used should be replaced before disassembly.
8. The bolt or screw length varies with assemblies and guards. Bolts or screws must be installed at correct positions. A bolt can be placed into a bolt hole for fitness in case of confusion.

## Important notes

1. Please use original parts made by Niu. Use of components that are not in compliance with design specifications by Niu Company may cause damages to the scooter.
2. Maintenance operations can be performed only with metric tools. The metric bolts, nuts and screws can not be interchanged with British fasteners.
3. The replacement with new washers, O rings, split pins and lock shims should be made for reassembly.
4. Bolts or nuts should be tightened by beginning with large-diameter bolts or inward bolts and then gradually tightening to specified torques diagonally, unless otherwise indicated.
5. Clean components that have been removed with the detergent solution. All the sliding faces should be lubricated before assembling.
6. Check all components for the proper installation and operating after assembly.
7. Remove the dirt and oil stains before measurement. Apply recommended lubricants to sections to be lubricated during assembly.
8. Apply the lubricant to part surfaces to avoid rusting and dust accumulation, if the engine and transmission systems need to be stored for a long time after disassembling.

## Cable connector inspection

- Loose cables constitute a risk to electric safety. Cables should be checked after their clamping to ensure electric safety.
- Bending of cable clamps towards welding points is not allowed.
- Cables are bound at designated positions.
- Cable placement at the scooter frame end or a sharp angle is not allowed.
- Cable placement at the bolt or screw end is not allowed.
- Cable placement should be made away from thermal sources or positions where cables may be stuck in moving.
- The cable placement along stem handles should not be made too tight or loose and should not interfere with adjacent parts at any steering positions.
- Cables should be placed smoothly without being twisted or tied.
- Verify whether the connector shroud is damaged or the connector is excessively open before connecting.
- Please protect the cable at a sharp angle or turning position with adhesive tapes or a hose.
- Cables should be bound reliably with adhesive tapes after reparation.
- Controlling cables should not be bent or twisted. The controlling would not be flexible if controlling cables were damaged.



## Importance Safety Notes

Make sure that you have completely understood basic workshop operation safety procedures and taken on proper protective clothes and are provided with safety equipment. Extra attention should be paid to the following in the implementation of a maintenance task:

- Read all the relevant instructions before operation, and make sure that you have necessary tools, spare parts, components and skills to implement a maintenance task safely and completely.
- There are high-voltage circuits in the scooter system, which can cause electric shock. It must be verified that your maintenance site, tools, protective equipment and operation procedures are in compliance with the insulation requirement.
- Eyes should be protected with proper safety glasses, goggles or masks in operations such as hammering, drilling, polishing or prying or working around high-pressure air or fluid tanks, springs or other energy storage components. Eye protection devices should be worn as long as there are suspicious conditions.
- Other protection devices such as gloves or safety shoes are used where necessary. Gloves should be worn before handling of a hot or sharp component that may cause serious burns or cuts or grasping of any things that may cause injuries.
- Measures should be taken to protect you and others once a scooter is lifted. Make sure that the scooter is always supported stably when being lifted with a crane or jacks. Please use jack mounts.
- The hot motor after driving for a long time may cause burns. Wait for the motor to cool down before working on it.
- Moving parts can cause injuries. Make sure that your hands, fingers and clothes are not obstructive.
- Components must be cleaned with non-flammable solvents instead of the gasoline.
- All components related to a storage battery should be away from cigarettes, sparks and flames.



# Part Names

- Vehicle Diagram with Part Names

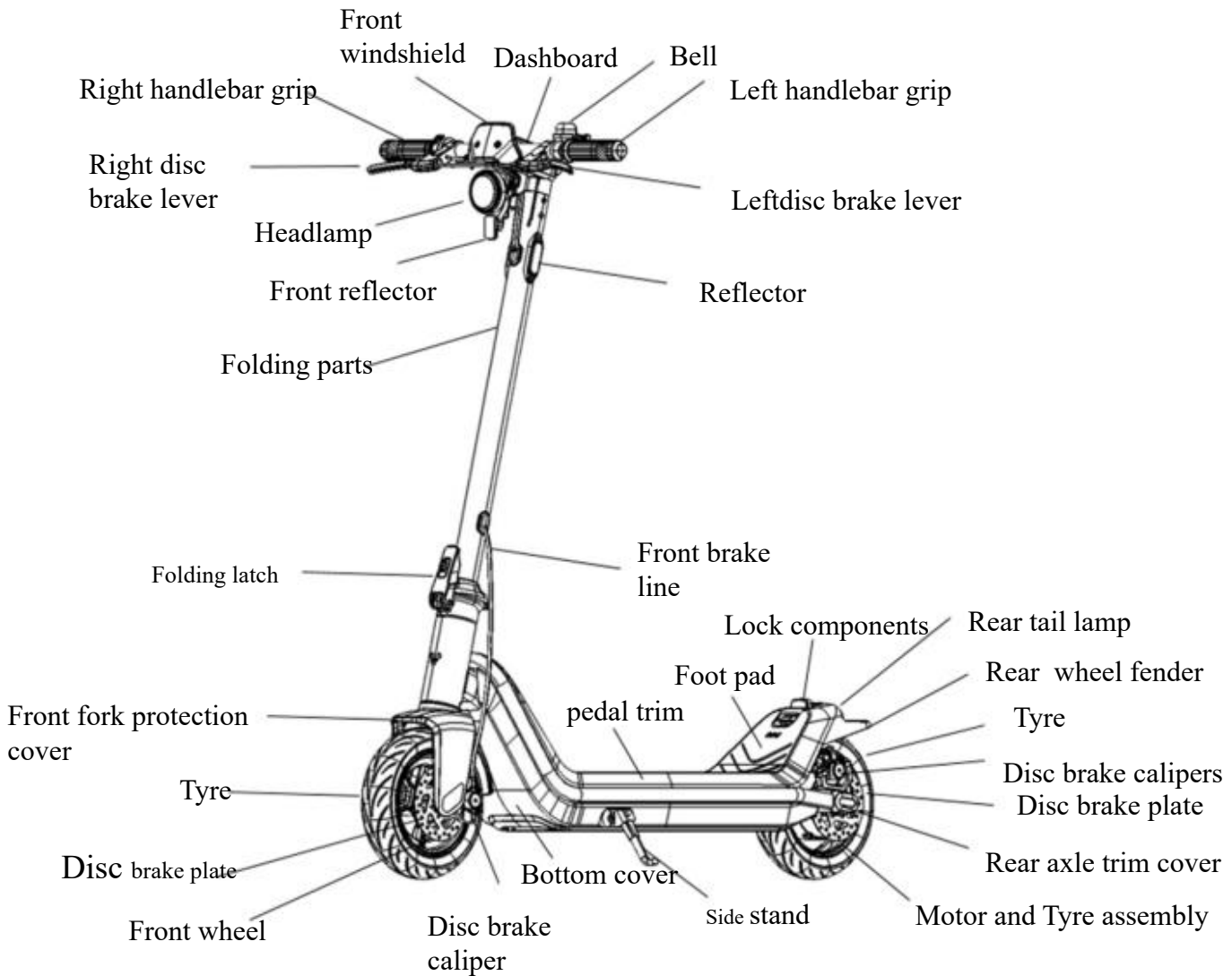



## Scooter Identification

- Vehicle serial number (SN) is in the user manual

Configuration Info	
SN	K320X12E720CC
Frame No.	19924210100
Battery No.	BK3HBB2X7200C
Battery specifications	47v 7 Ah
Number of Battery Cycles	1

- The scooter frame identification code (VIN) is made inside the frame.



The motor code is made at left side of the wheel-hub motor.





## Overall specifications:

Parameter Name	KQi3 Pro	KQi3 Sport	Remarks
Length	1,173mm	1,173mm	
Width	541.5mm	541.5mm	
High	1,202mm	1,202mm	
Length after folding	1,173mm	1,173mm	
Width after folding	541.5mm	541.5mm	
Height after folding	504mm	504mm	
Axle distance	890mm	890mm	
Ground clearance	76mm	76mm	
Pedal height	169mm	169mm	
Handle height	1,157mm	1,157mm	
Angle of folding riser to vertical distance	15°	15°	
Endurance mileage	Not less than 50KM	Not less than 40KM	25°C, without wind, 75kg body weight, flat asphalt road, measured at a constant speed of 15km/h
Turning radius	Minimum turning radius≤1.3m when walking your scooter Minimum turning radius≤2.5m at a speed of 10km/h Minimum turning radius≤3m at a speed of 12.5km	Minimum turning radius≤1.3m when walking your scooter Minimum turning radius≤2.5m at a speed of 10km/h Minimum turning radius≤3m at a speed of 12.5km	
Climbing ability (slope)	20% (slope)	15%	Condition: 75kg, riding uphill at a constant speed of 8±2km/h, driving distance not less than 5m





## Overall specifications:

Parameter Name	KQi3 Pro	KQi3 Sport
Allowable height of surface gathered water	≤65mm	≤65mm
Operating temperature of scooter	-10 - 45°C	-10 - 45°C
Battery capacity and specification	486.7Wh (10.4AH) lithium battery	365WH (7.8AH) lithium battery
Full charging time	6H	5h
Charging temperature range	Usable temperature range (0-40°C) Optimal temperature range (10-35°C)	Usable temperature range (0-40°C) Optimal temperature range (10-35°C)
Maximum battery storage time (50% electric quantity)	State as delivered (50% electric quantity) up to 180 days Battery exhausted state <60 days	State as delivered (50% electric quantity) up to 180 days Battery exhausted state <60 days
Brake method	Front- and rear-wheel dual mechanical disc brakes/rear wheel electronic brake	Front wheel mechanical disc brakes/rear wheel electronic brake
Braking distance	Double brake:≤4.4m (at a running speed of 20Km/h)	Double brake:≤4.4m (at a running speed of 20Km/h)
Headlight	Short-distance beam 6v 3w±15%, position 12v 2.26w±15%	Short-distance beam 6v 3w±15%, position 12v 2.26w±15%
Small bell	Percussion bell	Percussion bell
Motor rated power	350W	300W
Battery capacity	46.8V 486.7Wh	46.8V 365Wh
Driving mode	Rear drive	Rear drive
Waterproofing grade	Finished scooter IP54, battery pack (itself) IPX7, controller (itself) IPX7, motor IPX5	Finished scooter IP54, battery pack (itself) IPX7, controller (itself) IPX7, motor IPX5



## Overall specifications:

Structure division		KQi3 Pro	KQi3 Sport
<b>Weight information</b>	Net weight	20.3KG	18.4KG
	Gross weight	25.6KG (56.4lbs)	23.7KG (52.2lbs)
<b>Tyre</b>	Size of front wheel	9.5 inches (241mm)	9.5 inches (241mm)
	Tyre type	Rubber vacuum tyre	Rubber vacuum tyre
	Inflation pressure	50-60psi (shipping status)	50-60psi (shipping status)
	disc brake plate	120mm diameter brake disc	120mm diameter brake disc
<b>Body part</b>	Folding mechanism	Two stage protective folding mechanism	Two stage protective folding mechanism
	Body material	6061 aluminum alloy + welding	6061 aluminum alloy + welding
	Restriction of steering angle	Left and right 55°	Left and right 55°
<b>Dashboard</b>	Fault warning	Error symbols display on the digital tube, while warning tone comes from the buzzer	Error symbols display on the digital tube, while warning tone comes from the buzzer
	Unit display	Digital display on LED digital tube (mph and km/h are switchable)	Digital display on LED digital tube (mph and km/h are switchable)
	Speed display	Digital display on LED digital tube	Digital display on LED digital tube
	Electric quantity display	Digital display of electric quantity bar on LED digital tube	Digital display of electric quantity bar on LED digital tube
	Pedestrian mode	"Small foot" shape displays on LED digital tube	"Small foot" shape displays on LED digital tube
<b>Battery</b>	Voltage	46.8V	46.8V
	Capacity	486.7Wh (10.4AH)	365WH (7.8AH)
	Long storage temperature	0°C - 40°C	0°C - 40°C
<b>Motor</b>	Non-zero start	≥4KM/H	≥4KM/H
	Controller rated voltage	46.8V	46.8V
	Controller current limiting	17A±1A	14A±1A
<b>Charger</b>	Output current	2.0A max	2.0A max
	Output voltage	54.6V (53.5V)	54.6V (53.5V)



# Preparation

## Section 1

Maintenance qualification: Maintenance personnel must receive proper training .

Work environment: Indoor light intensity shall be  $1000 \pm 200$  Lux. The maintenance room must be isolated from daylight. Light must be evenly dispersed and directed vertically from above.

The maintenance room must be equipped with fire safety facilities, such as explosion-proof junction boxes, dry powder fire extinguishers, and fire buckets.

Tools:

Phillips screwdriver bits	PH0/PH1/PH2
Hexagon screwdriver bits	2.5/3/4/5/6 mm
Torx screwdriver bits	
Hexagon socket screwdriver bits	15/18 mm
Electric screw driver	With adjustable torque setting (0-50 N.m)
Ratchet wrench	15/18 mm
Valve core remover	(Standard)
Air compressor	150 PSI

## Storage

Please park your vehicle in a garage or in an open space.

If your vehicle is to be stored for a long time, please protect it from moisture and pressure. Regularly charge the battery to avoid deep sleep caused by prolonged storage.

## Note

- Do not damage scooter body coverages in disassembling/assembling.
- Do not damage hooks and claws on scooter body coverages in disassembling/assembling.
- Align the embedded panels and covers on scooter coverages with their respective grooves.
- Hooks and claws at various sections should be installed properly during assembly.

Procedures for removal and installation of scooter body parts are described in this section.

The ignition switch must be turned to OFF.



# forehead body

## Section 2

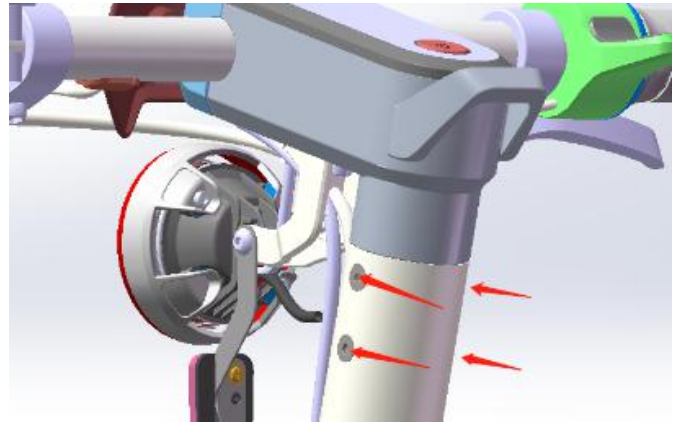

2.1 unsrew four Hexagon socket screws  
Related Screws: M5\*14 (H2001013)  
Mount: Follow as the reverse order.



2.2 remove the controller harness' line and the dashboard' line  
Mount: Follow as the reverse order. Insert as per indicated by the waterproof line arrow.



# forehead body

## Section 2

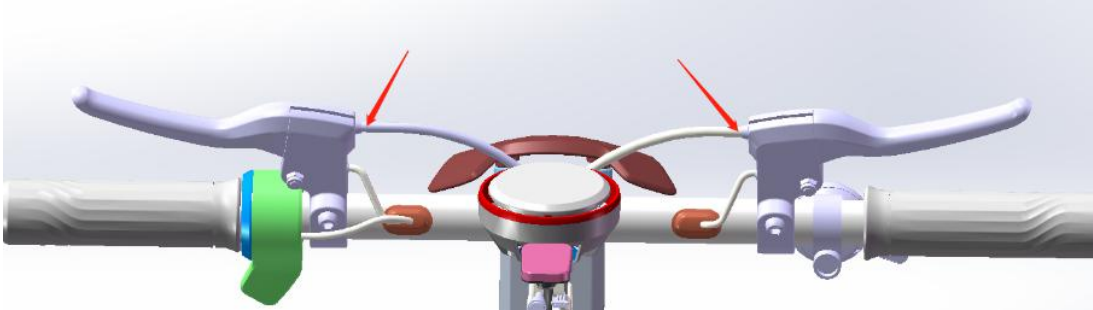

2.3 remove the front brake line and rear brake line  
Mount: Follow as the reverse order.



2.4 remove the forehead body  
Mount: Follow as the reverse order.





# dashboard and dashboard cover

## Section 3

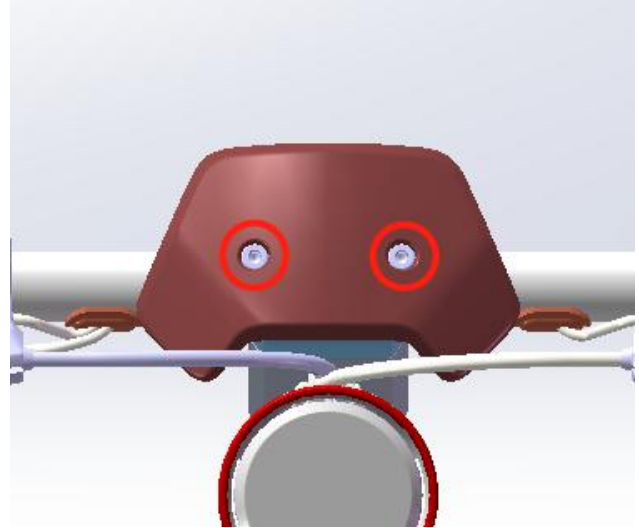

3.1 remove the front windshield: unscrew two Hexagon socket screws

Related Screws: M5\*12 (H2001009)

Mount: Follow as the reverse order. There shall be no shaking clearance while shaking the front windshield with one hand.

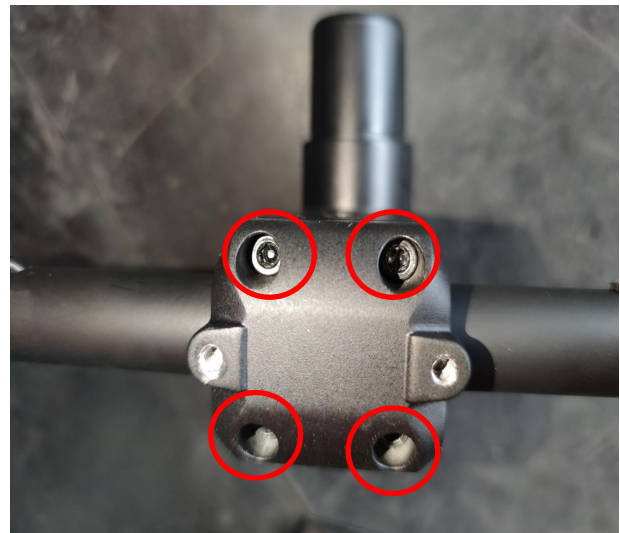
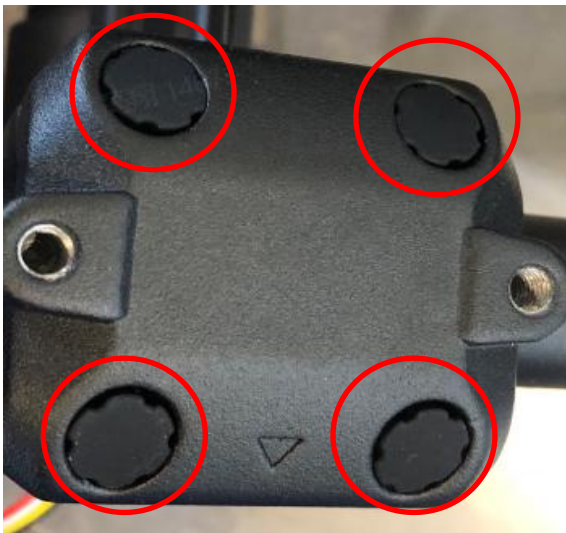

3.2 remove four silicone plugs, unscrew four Hexagon socket screws

Related Screws M5\*18 (H2001006)

Mount: Follow as the reverse order.



# dashboard and dashboard cover

## Section 3



3.3 remove the forehead locking cover

Mount: Follow as the reverse order. Install upwards as per indicator arrow.

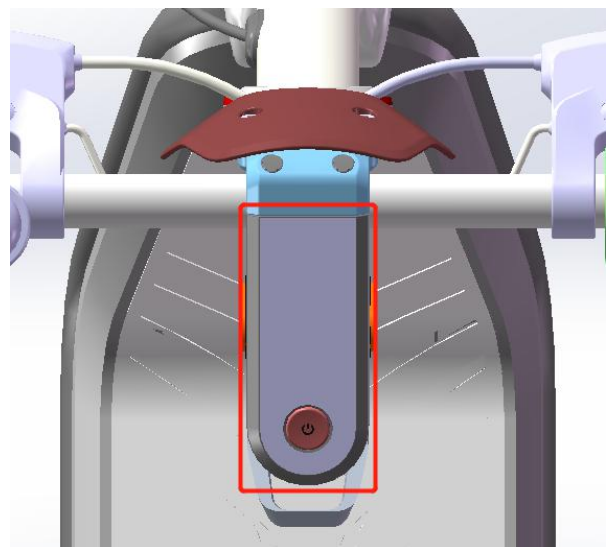

3.4 remove the dashboard cover: tear off the dashboard cover

Mount: Follow as the reverse order.



# dashboard and dashboard cover

## Section 3

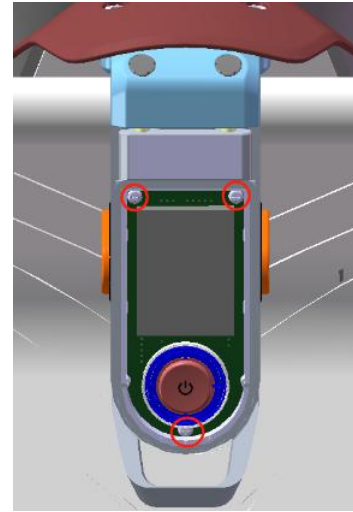

3.5 unscrew three cross screws,remove the dashboard from the forehead body

Related Screws: M2\*8 (H2001008)

Mount: Follow as the reverse order.

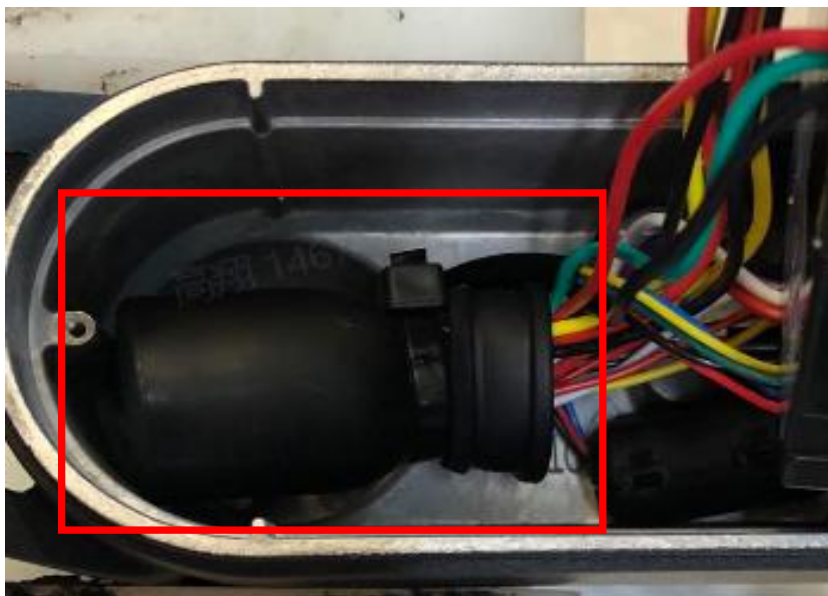

3.6 cut the fastening tie,remove the harness sleeve  
Mount: Follow as the reverse order.





# dashboard and dashboard cover

## Section 3



3.7 remove the dashboard: remove four connectors  
Mount: Follow as the reverse order. Press the switch button to power on and check whether the startup is normal.



3.8 separate the forehead body and the handlebar  
Mount: Follow as the reverse order.



# headlamp

## Section 4



4.1 remove the forehead midhole plug, Notice that the side close to the handlebar shall be with radian, and the rear shall be flat.

Mount: Follow as the reverse order.



4.2 unscrew two Hexagon socket screws

Related Screws: M5\*12 (H2001009)

Mount: Follow as the reverse order.



# headlamp

## Section 4

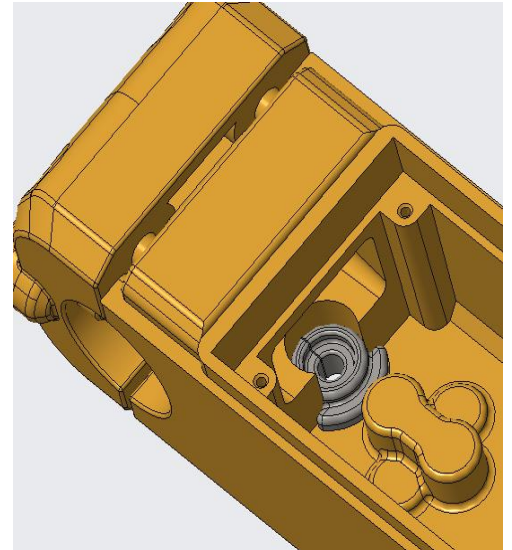

4.3 remove the headlamp wire plug,remove the headlamp  
Mount: Follow as the reverse order.



# headlamp

## Section 4

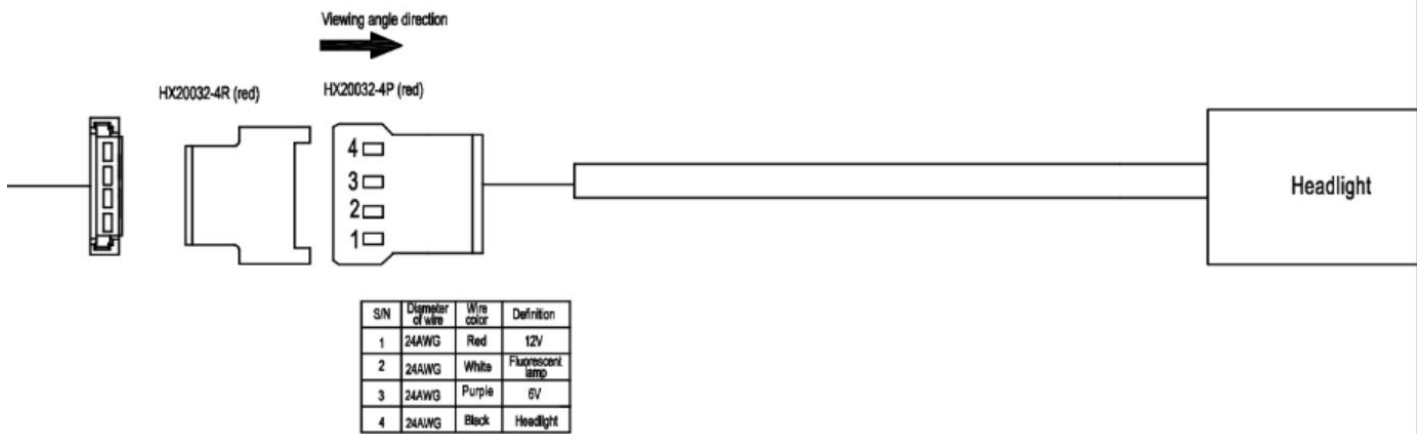





# handlebar

## Section 5

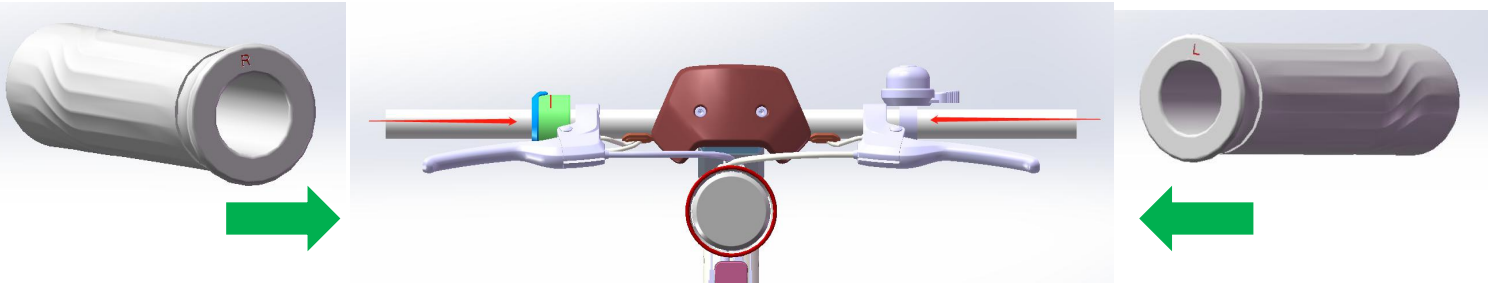

5.1 remove handlebar grips: Pull the left and right handlebar grips with force away from the handlebar. Mount: Follow as the reverse order. There shall be no cavity left at the end of the handlebar grips, and the handlebar grips shall be not rotated while screwing the handlebar grips with one hand with force .



# handlebar

## Section 5

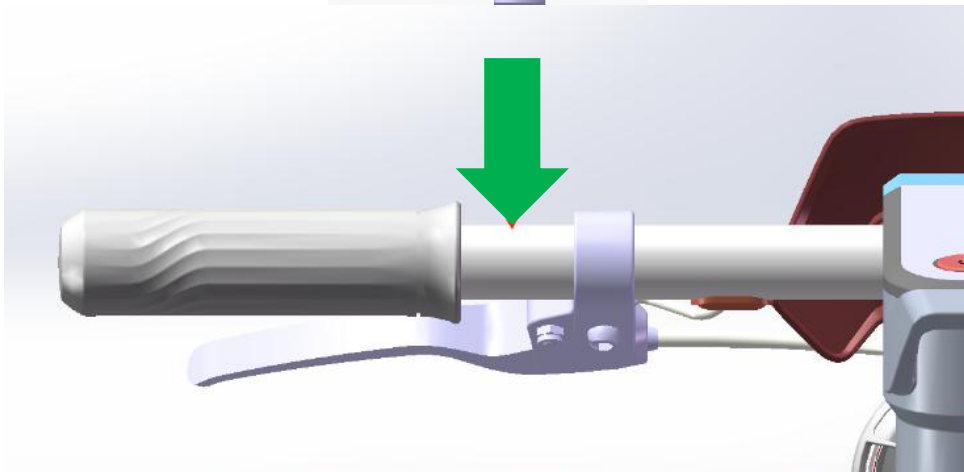
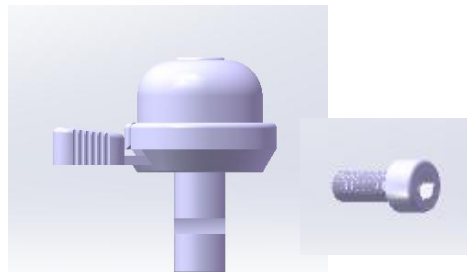
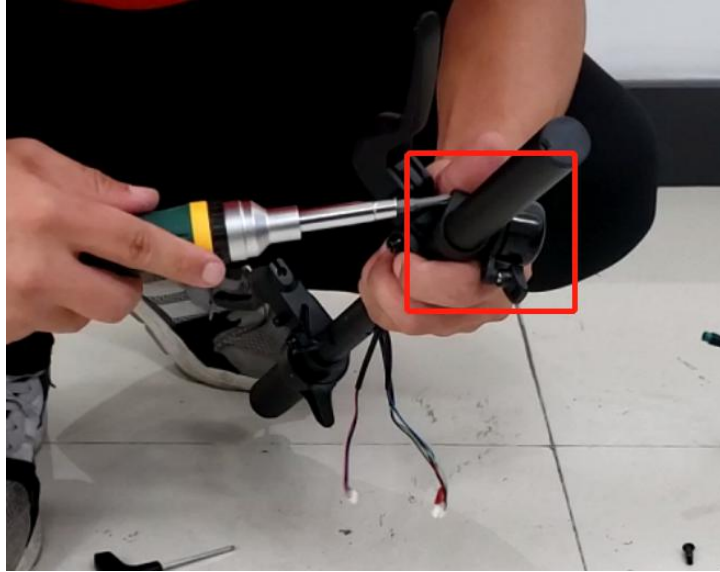

5.2 unscrew the screw,remove the bell  
Mount: Follow as the reverse order. There shall be no shaking clearance while shaking the bell with one hand; Grip it naturally with one hand, and the bell can be rung easily with the thumb .



# handlebar

## Section 5



5.3 remove the Left disc brake lever: unscrew the screw, remove the handlebar threading plug  
Mount: Follow as the reverse order. Preload the disc brake.



# handlebar

## Section 5

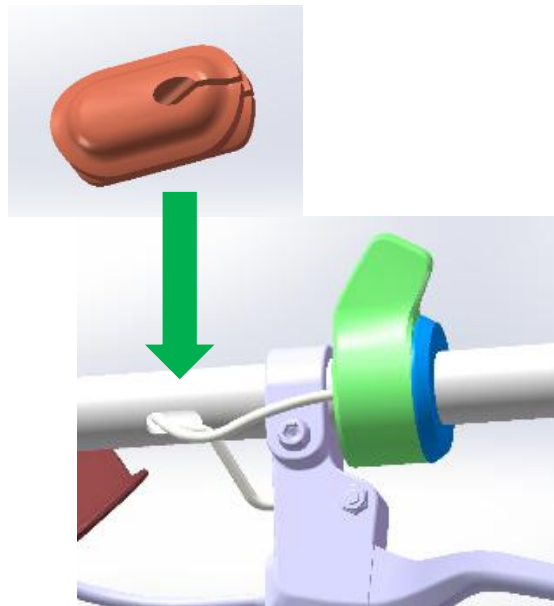
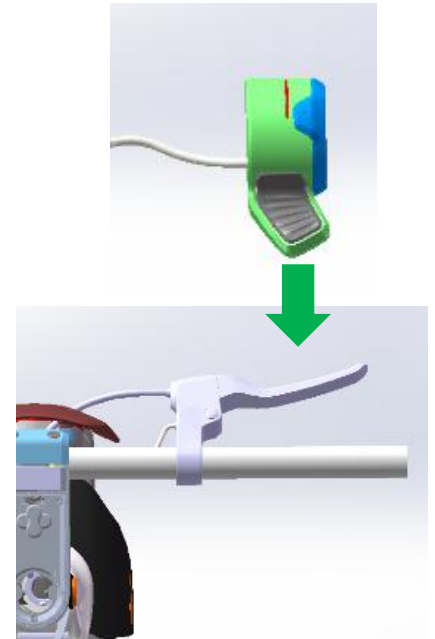

5.4 remove the finger control throttle bar : unscrew the screw, remove the handlebar threading plug  
Mount: Follow as the reverse order.





# handlebar

## Section 5

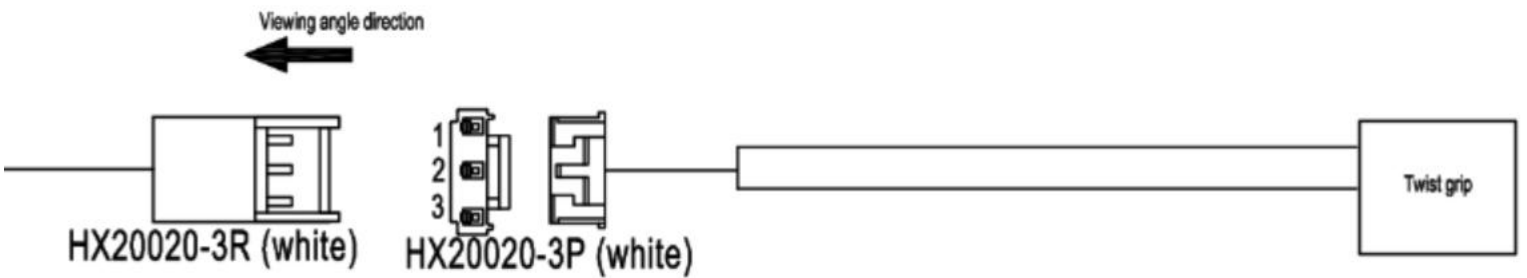

S/N	Diameter of wire	Wire color	Definition
1	24AWG	Red	4.3V
2	24AWG	Green	BK
3	24AWG	Black	GND



# handlebar

## Section 5



5.5 remove the Left disc brake lever : unscrew the screw Mount: Follow as the reverse order.Preload the disc brake.



# handlebar

## Section 5

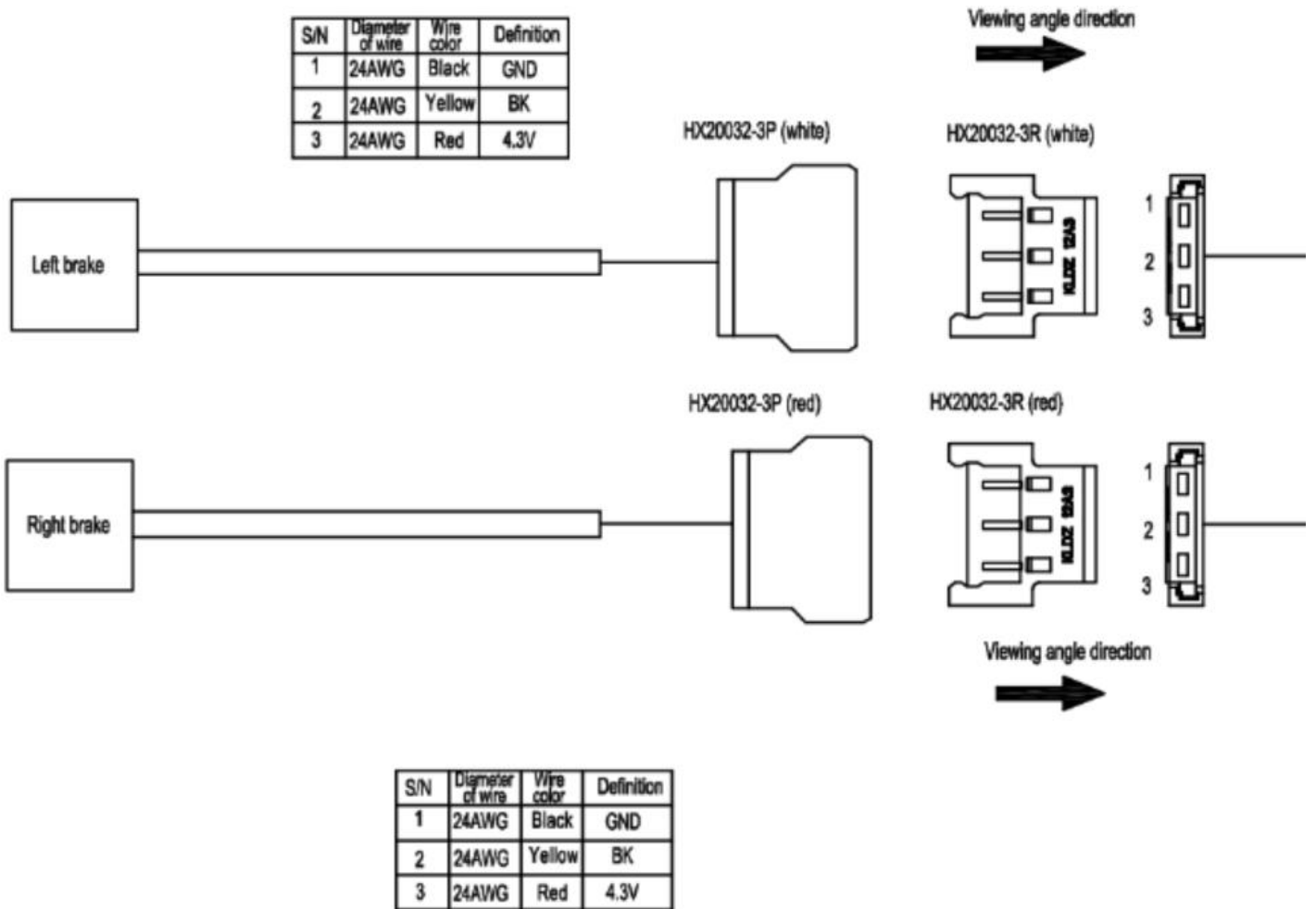



# pedal

## Section 6

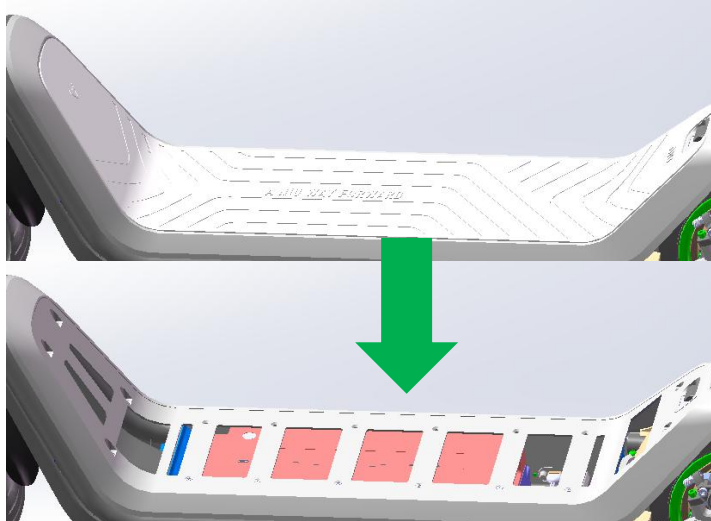

6.1 remove the pedal pad: Tear off the foot pad with force and remove the adhesive from the pedal pad left on the scooter body.

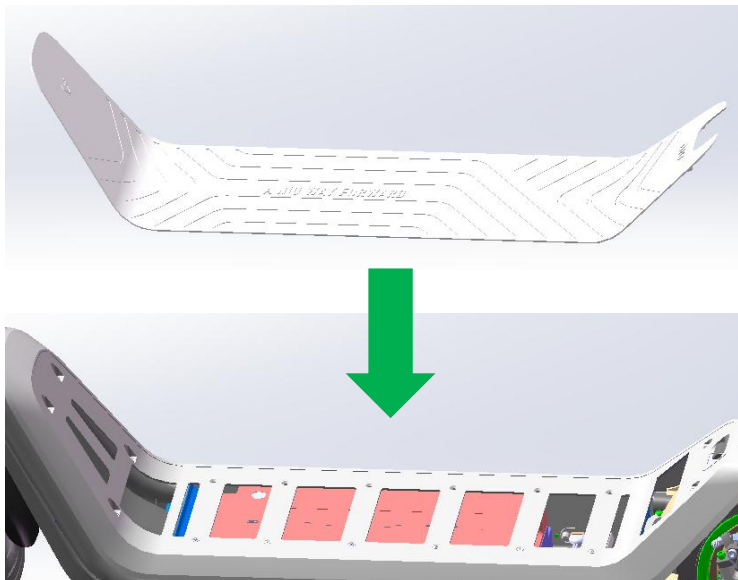

Mount: Follow as the reverse order.

1, Wipe the scooter body clean, and there shall be no adhesive residue, water and oil stain and other fouling.

2, Tear off the bottom surface of the adhesive surface of the pedal pad and lay it on the pedal trim slowly to ensure that there are no bubbles and no deflection .



# pedal

## Section 6

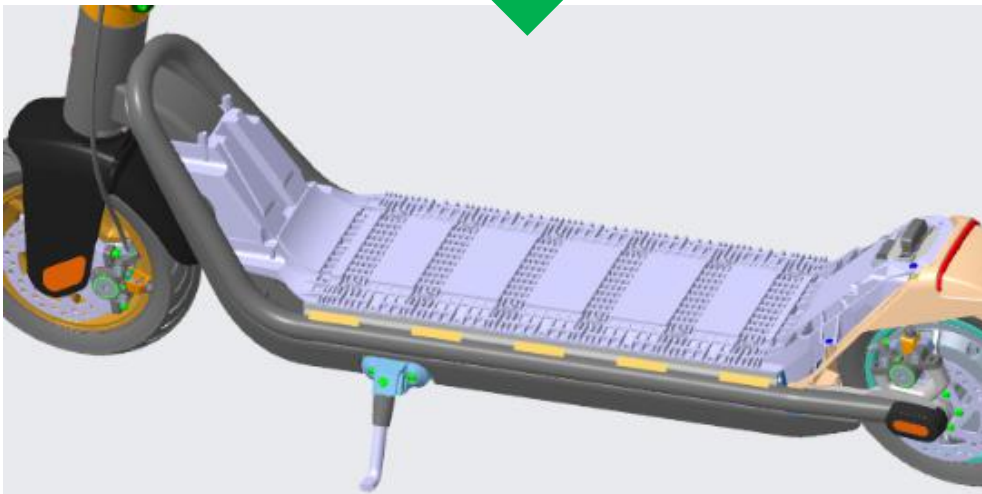
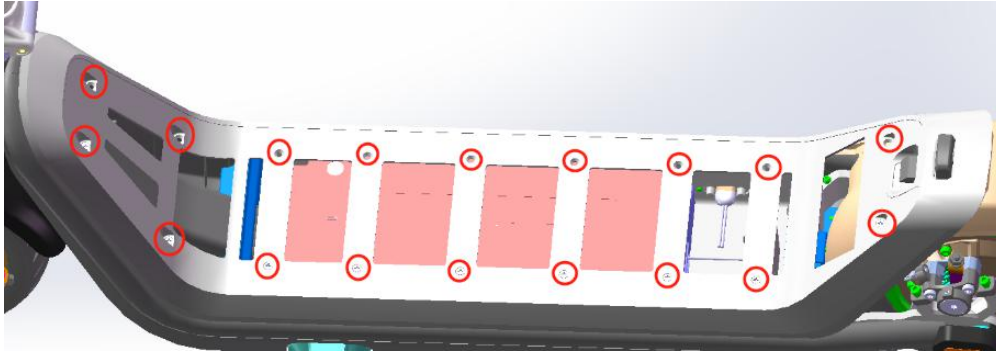

6.2 remove the pedal trim: unscrew eighteen cross screws

Related Screws: ST3.5\*9.5 (H2002005)

Mount: Follow as the reverse order.



# pedal

## Section 6



K3 pedal long foam

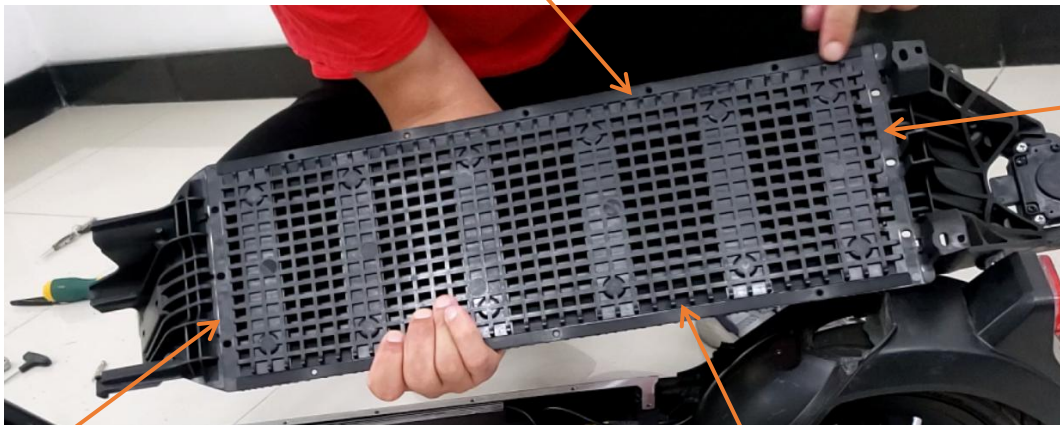

K3 pedal short foam

K3 pedal short foam

K3 pedal long foam

6.3 remove the pedal trim: unscrew twenty Hexagon socket screws and eight cross screws

Related Screws: M4\*8 (H2001001) ST4.2\*16 (H2002004)

Mount: Follow as the reverse order.





# pedal

## Section 6



6.4 remove the lock components: unscrew four cross screws

Related Screws: ST4.2\*16 (H2002004)

Mount: Follow as the reverse order.



# controller and battery pack

## Section 7

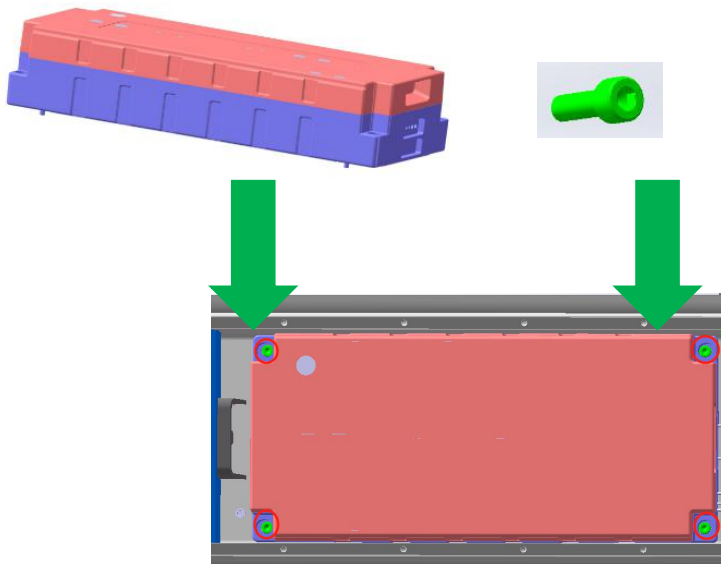
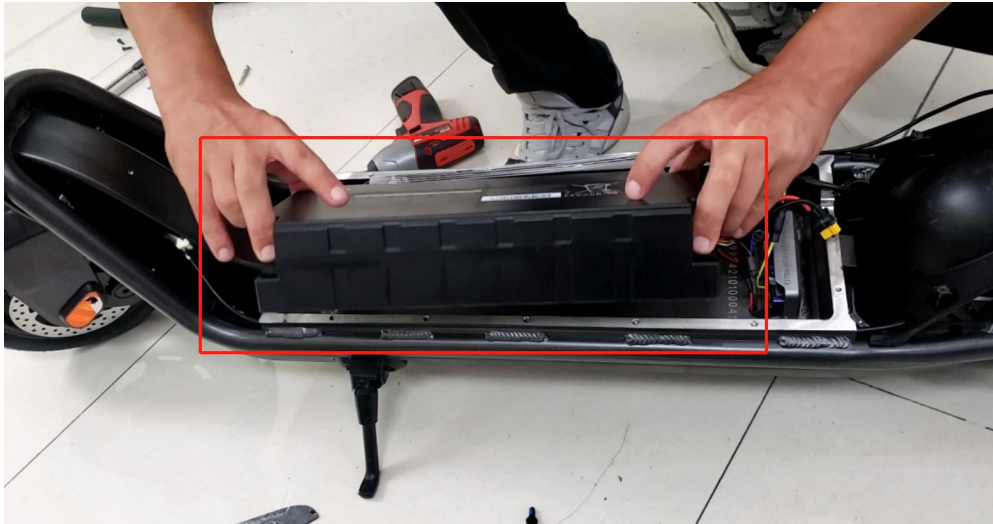

7.1 remove the battery pack: unscrew four Hexagon socket screws

Related Screws: M5\*18 (H2001016)

Mount: Follow as the reverse order.





## Lithium battery

### Note

The Power Lock and Main Switch should be turned off before removal of electronic components.

The battery used for this model is a lithium battery.

Remove the battery from scooter storage for than a week, Charge the battery to approximately 50% of its capacity and store it at a room temperature.

Perform periodical charging of the battery every month. The long-term storage of battery in below 20% of the electricity is strictly prohibited.

The battery should be fully charged for use after long-term storage.

The original battery for this model must be charged with the original charger that accompanies with the scooter (the scooter charging with a non-original charger will cause irrecoverable damages to the battery). Charging with a non-original charger may lead to the circuit or battery failure.

Stop charging immediately if the battery has not been fully charged for more than 24 hours and the red lamp does not turn to green, and then contact the after-sale service for inspection of the charger and battery.



# controller and battery pack

## Section 7

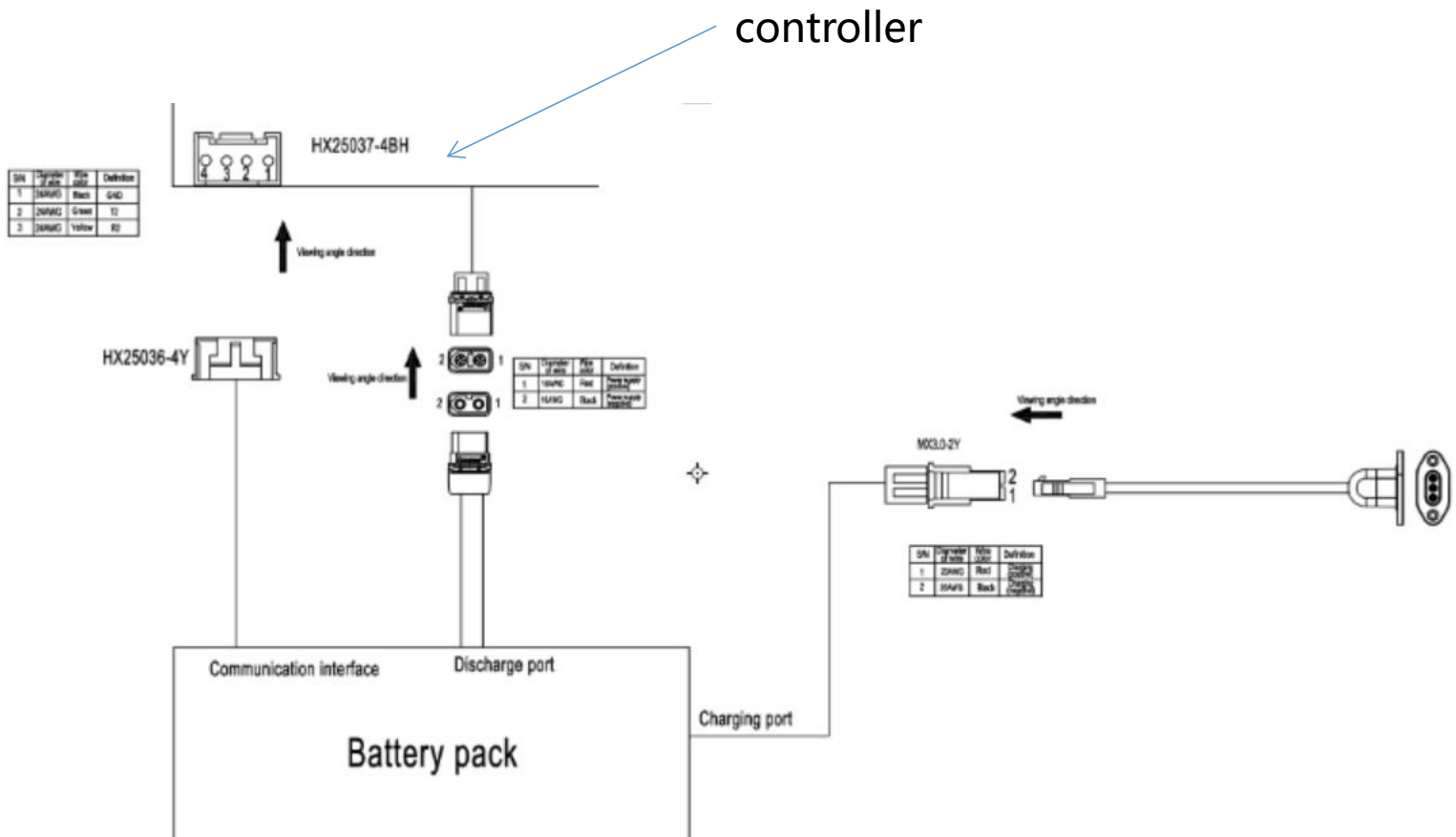



# Lithium battery

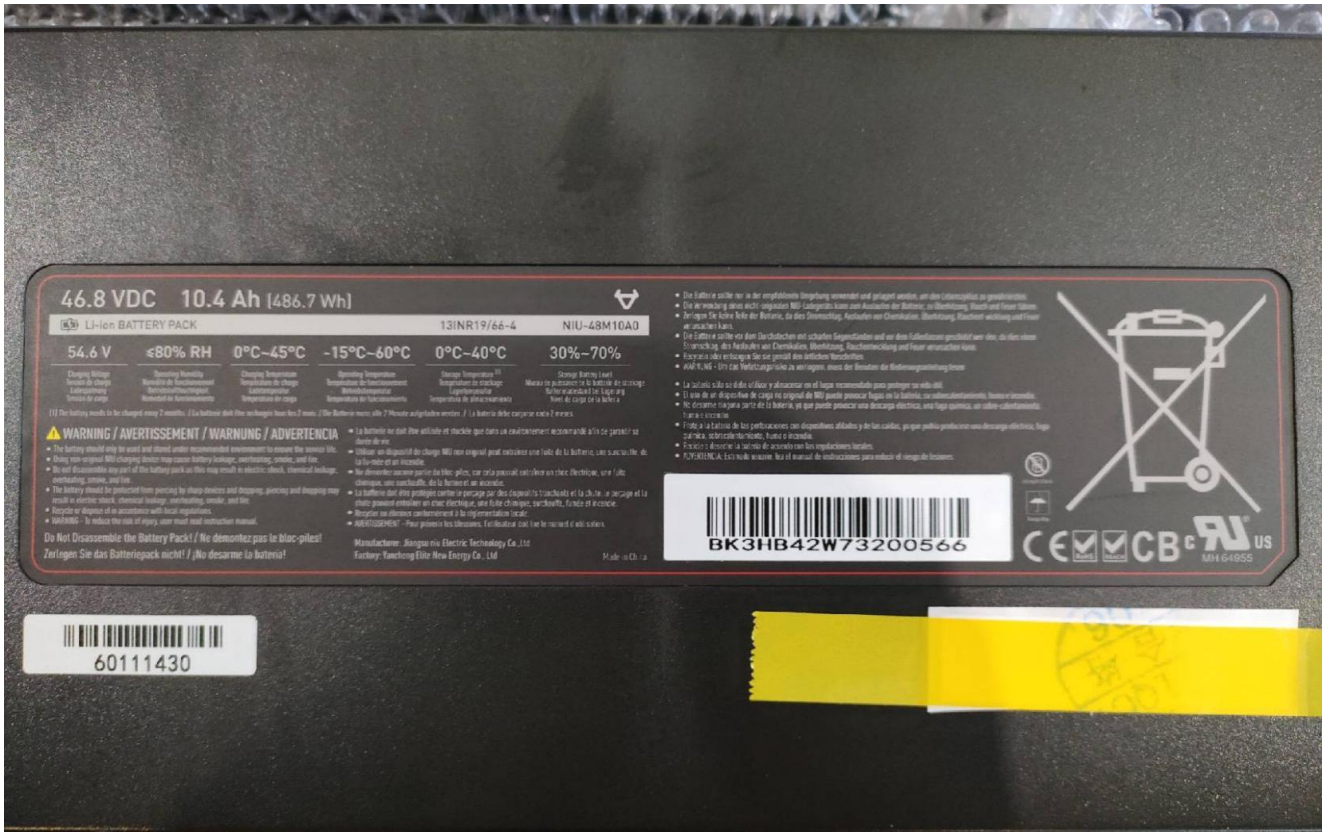

## pro version



## sport version



# controller and battery pack

## Section 7

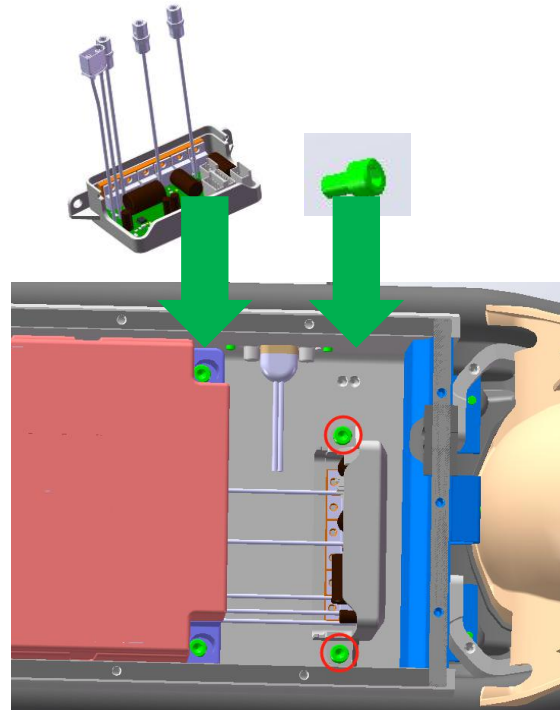

7.2 remove the controller: unscrew two Hexagon socket screws

Related Screws: M5\*8 (H2001012)

Mount: Follow as the reverse order. Apply heat conductive silicone grease on the bottom surface.



## FOC Controller

### Main protective functions

#### 1. Current limit protection

The maximum controller output current is limited to protect the motor, controller, battery and other components from being damaged by a current greater than specified.

#### 2. Rotation failure (overload) protection

The controller judges the motor status automatically in a certain period of time after the motor rotation failure (over-current) occurs. It controls automatically the output current to protect safety of the motor, controller and battery.

#### 3. Under-voltage/over-voltage protection

The controller stops automatically the motor rotation when the input voltage to motor is lower or higher than the set value, in order to protect safety of the motor and extend the battery lifetime.

#### 4. Power cut-off protection in charging or braking

The controller stops the motor automatically to avoid unexpected injuries when the vehicle is being braked or charged.

#### 5. Control loss protection

The controller stops the motor automatically to avoid unexpected injuries when the Hall cable sensor or its circuit fails and is out of control. The functions such as motor temperature protection, controller temperature protection and motor winding short protection are also provided.





# controller and battery pack

## Section 7



7.3 remove the charging assembly: unscrew two Hexagon socket screws

Related Screws: M4\*8 (H2001001)

Mount: Follow as the reverse order.

7.4 remove the charging port: unscrew two cross screws

Related Screws: ST2.9\*13 (H2002001)

Mount: Follow as the reverse order.



# controller and battery pack

## Section 7

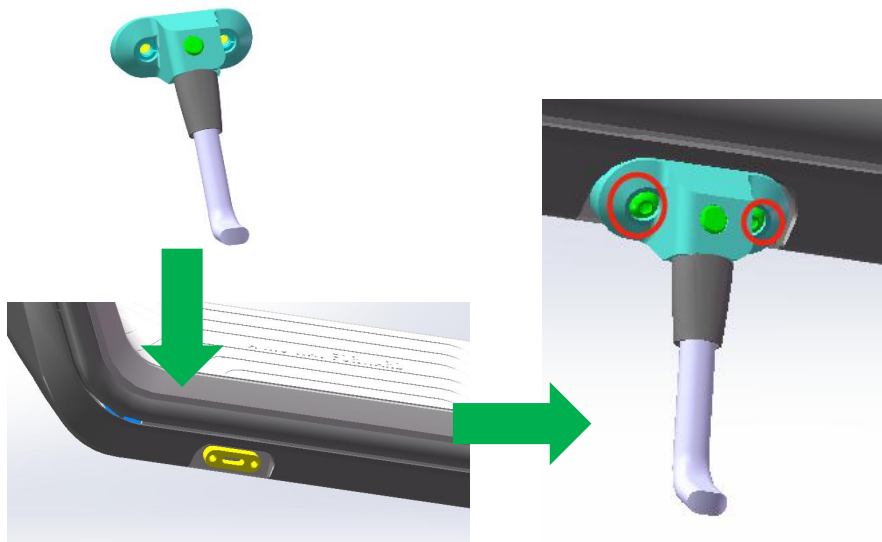

7.5 remove the Side Stand: unscrew two cross screws  
Related Screws: M6\*12 (H2002001)  
Mount: Follow as the reverse order.



# rear wheel and rear wheel fender

## Section 8



8.1 remove the rear axle trim cover: tear off decorative cover reflective stickers, unscrew two Hexagon socket screws  
Related Screws: M5\*16 (H2001004)  
Mount: Follow as the reverse order.

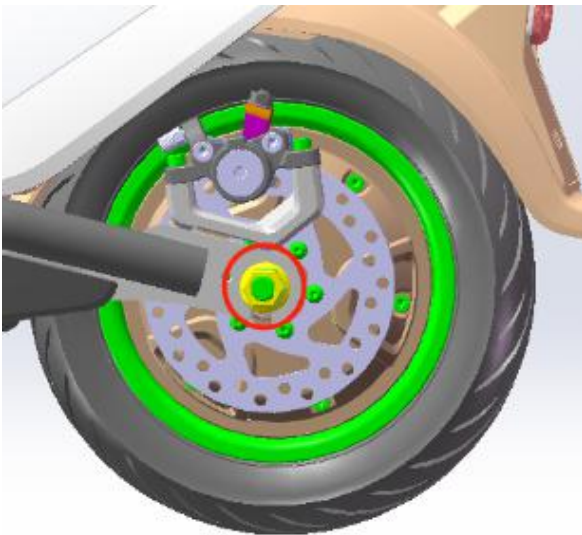

8.2 remove the motor: unscrew two Hexagon Nuts  
Mount: Follow as the reverse order. The motor line shall be on the right.



Notice that the direction arrow of the disc brake plate shall be consistent with the direction of the tyre grain.





# rear wheel and rear wheel fender

Section 8



Check left side: disc brake plate, flat pad (supplied), anti-rotation gasket (supplied), and lock nut (supplied);

The right side : flat pad (supplied), anti-rotation gasket (supplied), lock nut (supplied);

The outlet direction of the motor line shall be straight ahead and the anti-rotation gasket facing inward and downward;

There is no disc brake plate if it is a Sport version.



# rear wheel and rear wheel fender

## Section 8

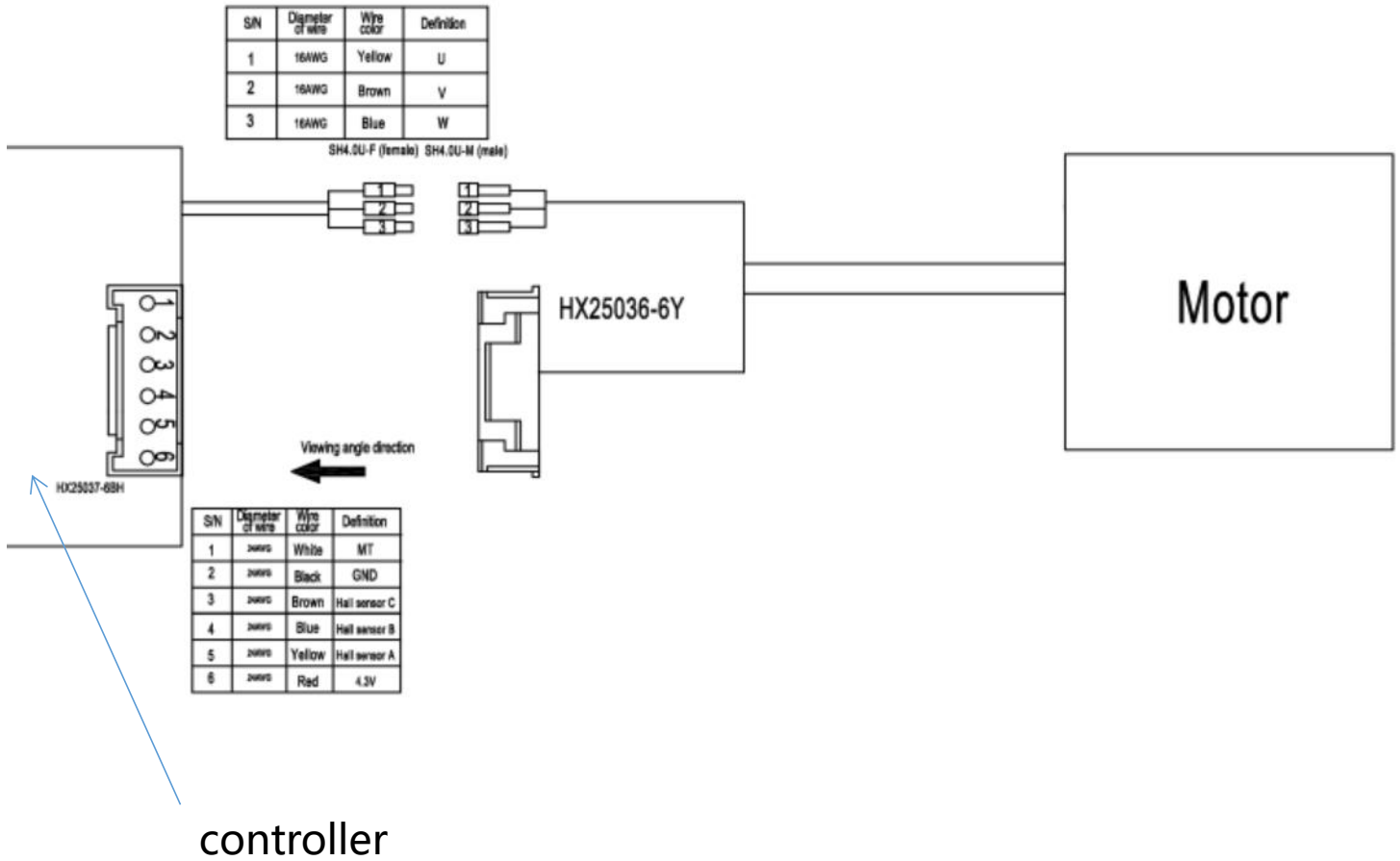



## Electrical System

### Motor

The motor used in this scooter is an efficient brushless DC motor with a permanent magnet made of rare earths, which is integrated with the rear wheel.

The motor does not require maintenance in daily riding. However, attention should be paid to the status of installation and tightening nuts on the motor shaft.

The motor is integrated with the rear wheel. Attention should be paid to inspection of the tire pressure during maintenance. Driving at insufficient tire pressure will cause damages to the motor hub.

The motor should be stopped immediately when the motor is abnormally hot, smoking, smelling abnormally, sounding abnormally or has other abnormal conditions.

Check the battery for normal performance and make it charged fully before maintenance of the motor system.

Check the Hall cable sensor connector, Hall motor connector and controller connector for shorting due to moisture, looseness or bad contact before maintenance of the motor system. Attention should be paid to proper maintenance of the motor system and appropriate protection measures for avoidance of the electric shock, since the high current and voltage are involved.

The Hall cable sensor and Hall motor sensor should be inspected for shorting before replacement of the damaged controller with a new one, otherwise the new controller that has been installed will get damaged again.

The motor temperature rises higher and faster in a high-altitude area than in a plain area. Thus the scooter operating for a long time will easily result in the situation where the motor becomes abnormally hot and even the motor fails.

Pay attention to the wire polarity in installing the battery or controller.



# rear wheel and rear wheel fender

## Section 8



8.3 remover the Disc brake caliper: unscrew two Hexagon socket screws

Related Screws: M5\*16 (H2001004)

Mount: Follow as the reverse order.

8.4 Loosen the lock nut of the brake line and pull the brake line out from the hole

Mount: Follow as the reverse order.



## **Brake failure diagnosis**

The brake performance is not good.  
The brake is not adjusted properly.  
The brake pad and brake disc are worn.  
The brake assembly is not installed properly.  
The brake pad and brake disc are contaminated.  
The brake responds slowly or the handle is tight.  
The brake is not adjusted properly.  
The brake pad and brake disc are worn.  
The brake assembly is not installed properly.  
There is an abnormal noise from the brake.  
The brake pad and brake disc are worn.  
The brake pad and brake disc are contaminated.  
The brake pad is worn.  
The brake caliper is dirty.  
The brake caliper does not slide smoothly.  
The brake pad is bent and deformed.

## **Disassembling**

Replace the brake pad assembly.  
If the brake pad assembly will be used again, then it should be marked at side before removal so that it can be installed at its original position.

There should be no oil stains on the Front/Rear hydraulic brake pad assembly in installing or removal.  
The cleaning should be made with a specified detergent to avoid reduction of the brake performance.  
Remove the brake disc from the Front/Rear wheel.





# rear wheel and rear wheel fender

Section 8

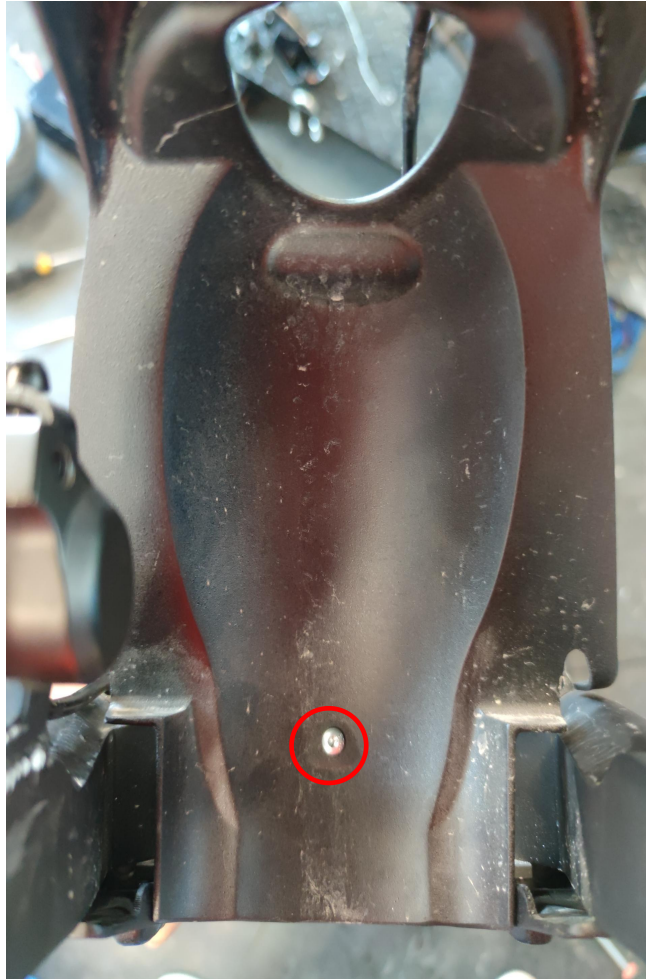

8.5 remove the rear wheel fender: unscrew one Hexagon socket screw

Related Screws: M4\*8 (H2001001)

Mount: Follow as the reverse order.



# rear wheel and rear wheel fender

Section 8



8.6 remover the tail lamp line guard: unscrew two cross screws

Related Screws: ST4.2\*13 (H2001015)

Mount: Follow as the reverse order.

8.7 remover the tail light adapter plate: unscrew two cross screws

Related Screws: ST4.2\*13 (H2001015)

Mount: Follow as the reverse order.



# rear wheel and rear wheel fender

## Section 8



8.8 remove the rear tail lamp: unscrew one cross screw  
Related Screws: ST4.2\*13 (H2001015)  
Mount: Follow as the reverse order.



8.9 separate the rear tail lamp and the tail lamp adapter line  
Mount: Follow as the reverse order.



# rear wheel and rear wheel fender

## Section 8

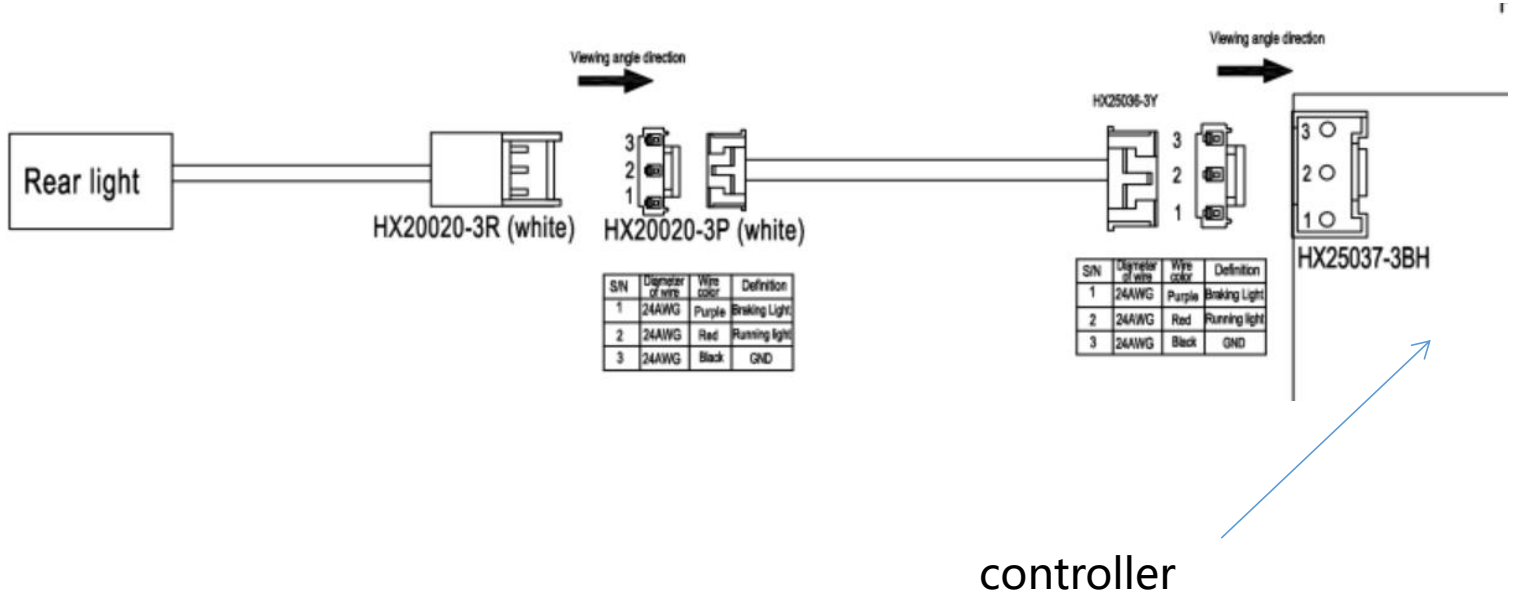



# folding parts

## Section 9



9.1 remove the brake line upper plug and the brake line lower plug,remove the Front brake line,put down the folding parts assembly.

Mount: Follow as the reverse order.





# folding parts

## Section 9



9.2 unscrew the Folding parts fixed screw  
Related Screws: M35\*1.5 (H2001010)



Mount: Follow as the reverse order. The Folding parts fixed screw shall be parallel to the red line, otherwise it may not be able to be closed.



# folding parts

## Section 9



9.3 remover the folding parts assembly: unscrew two screws  
Mount: Follow as the reverse order.

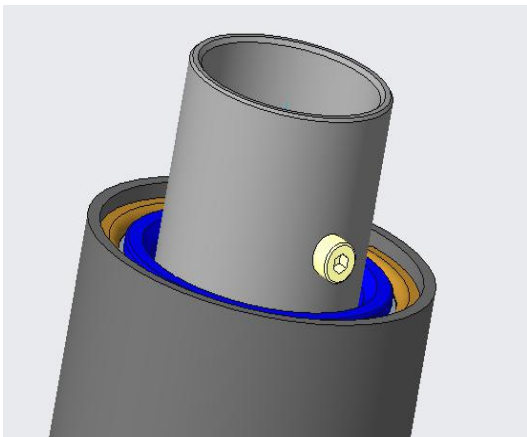

9.4 unscrew one Hexagon socket screw, remove the front fork

Related Screws: M4\*10 (H2001014)

Mount: Follow as the reverse order.



# folding parts

## Section 9

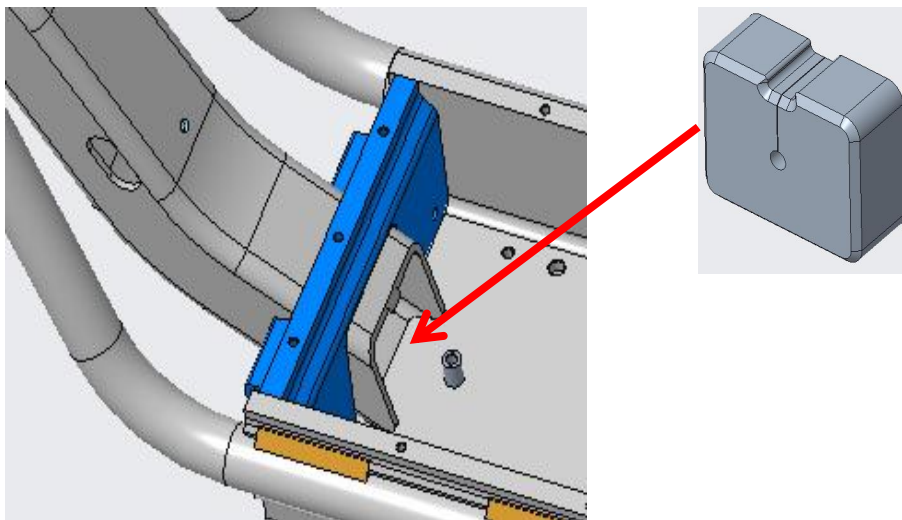
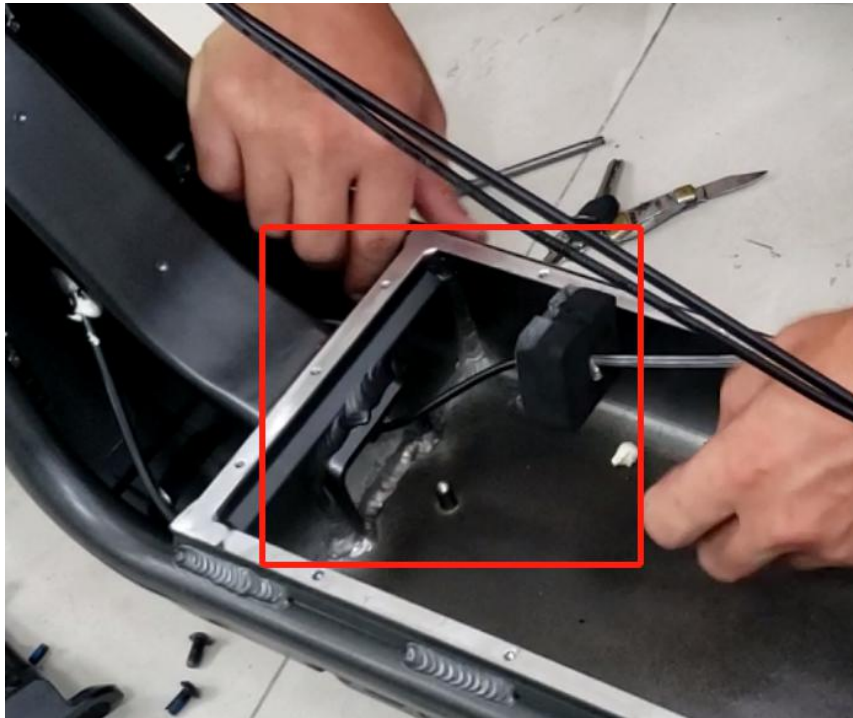

9.5 remove the waterproof foam from the frame,remove the controller harness,rear brake line and the wire guard spring, separate the frame and the front fork.  
Mount: Follow as the reverse order.



# front fork and front wheel

Section 10



## 10.1

From the bottom to the top, successively they are: the direction bearing bead assembly, the dust ring , lower head upper plug and the opening holding ring, the spherical surface shall face downwards

Mount: Follow as the reverse order.





# front fork and front wheel

Section 10



10.2 From the bottom to the top, successively they are: lower head bowl plug, the dust ring, the direction bearing bead assembly, the spherical surface shall be kept facing upwards, and the lower head bowl plug needs to be pressed on the front fork.

Mount: Follow as the reverse order.





# front fork and front wheel

## Section 10



10.3 tear off front reflective stickers,unscrew two Hexagon socket screws,remove front axle trim covers  
Related Screws: M4\*10 (H2001014)  
Mount: Follow as the reverse order.



10.4 remover the front fork protection cover: unscrew two Hexagon socket screws  
Related Screws: M4\*8 (H2001001)  
Mount: Follow as the reverse order.



# front fork and front wheel

Section 10



10.5 remove the bottom cover: unscrew four Hexagon socket screws, Break off 5 pairs of buckles.  
Related Screws: M4\*8 (H2001001)  
Mount: Follow as the reverse order.



10.6 remove the self-tapping screw plate: Straight upwards to remove the card  
Mount: Follow as the reverse order. The flat side shall be outward



## Charger

### Overview

The charger will generate heat during charging. It should be subject to good ventilation and radiation.

The battery and charger must not be covered.

They must not be close to flammable or explosive objects in charging to avoid the explosion or fire that may cause personal injuries.

There is high-voltage current in the charger during charging. The charger is strictly prohibited from being opened in order to prevent electric shock.

The charging should be made indoor and should not be made at an open site in order to prevent the electric shorting or firing due to rain and other factors.

The charging process is strictly prohibited from being made in a rainy, exposure or high-temperature environment or close to fire sources.

Only original charger and a stable 100-240V AC power supply should be used in charging.

The polarity of the charger output connector must be consistent with the battery output connector, otherwise the charger and battery will be damaged.

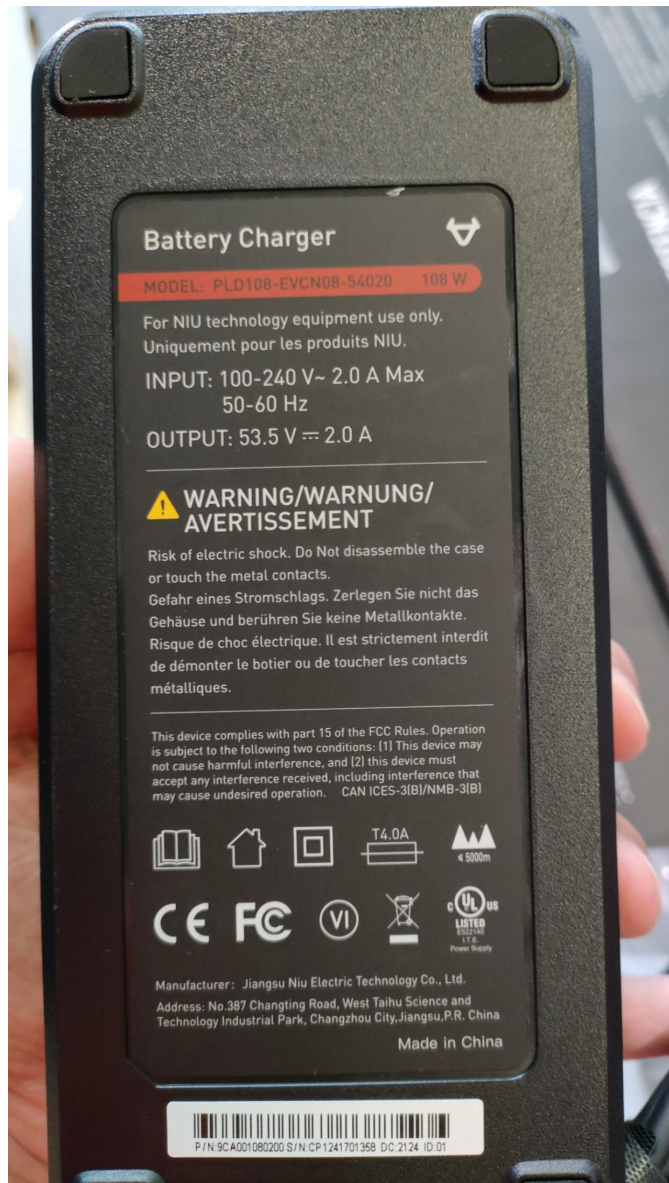



# Wiring Diagram

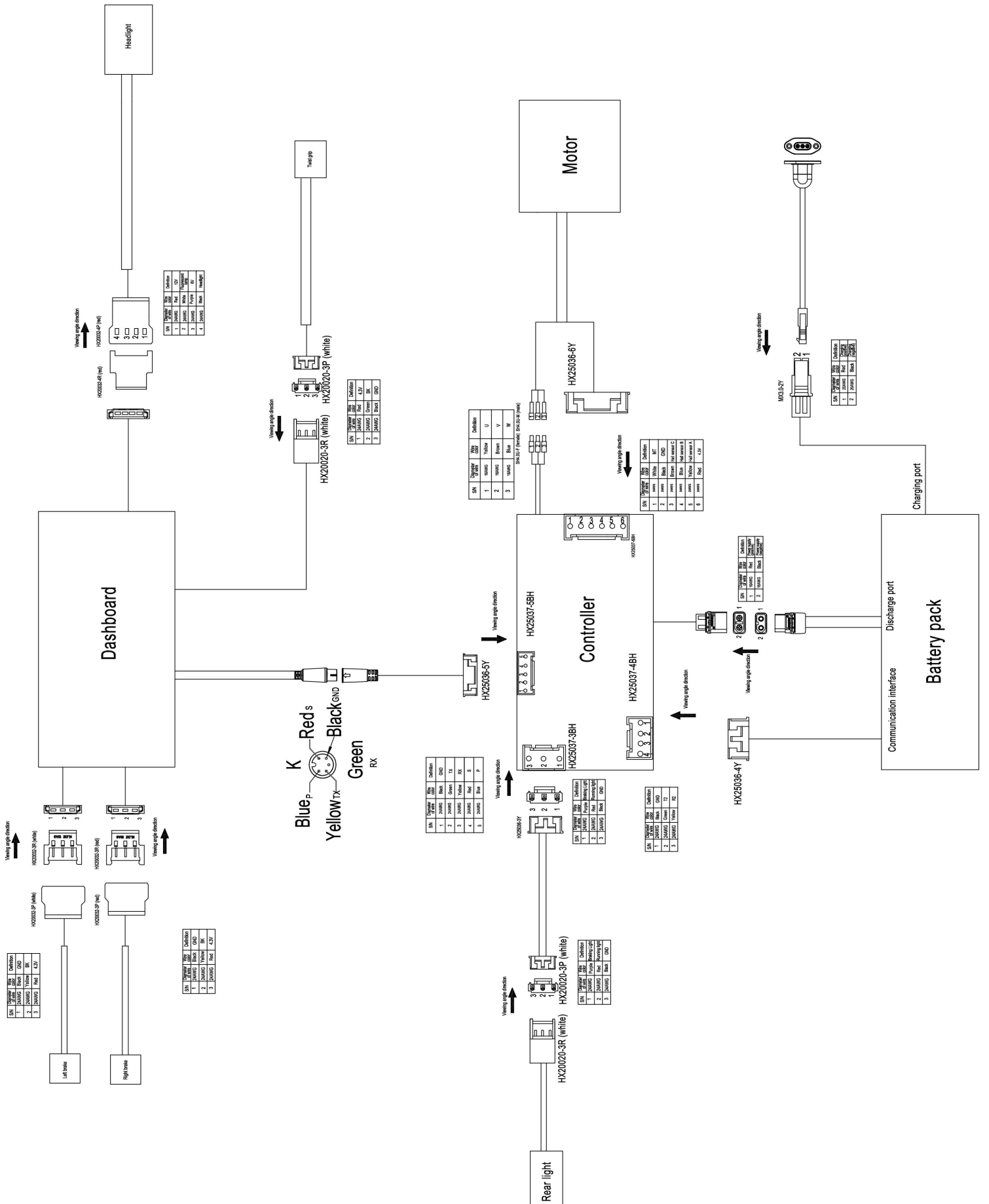





# Fault Codes

Dashboard Display and Screen Display in the Event of a Vehicle Fault

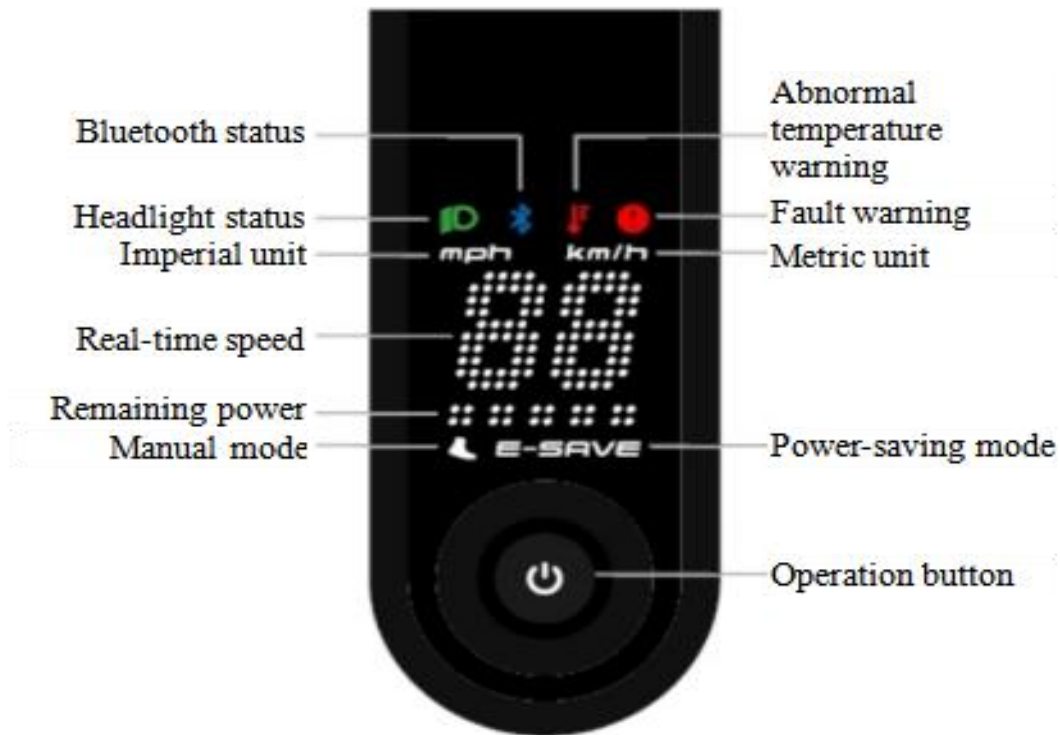





# Fault Codes and Corresponding Measures

No.	Description of Fault	Measure
01	Controller MOSFET fault	Please contact after-sales service
02	Brake fault	Please check the status of the brake handle or contact after-sales service
03	Throttle failure	Please check the throttle switch status or contact after-sales service
04	Controller overcurrent	Please contact after-sales service
05	Controller overheated	Let the vehicle stand and use only after internal temperature returns to normal
06	Controller power supply failure	Please contact after-sales service
07	Controller communication/verification failure	Please contact after-sales service
08	FOC undervoltage or overvoltage	Please charge the vehicle or contact after-sales service
10	Motor stalled	Please contact after-sales service
11	Motor phase loss	Please contact after-sales service
12	Motor malfunctioning	Please contact after-sales service
13	Motor overheat	Let the vehicle stand and use only after internal temperature returns to normal
31	Battery MOS damaged	Please contact after-sales service
32	Battery exposed to water	Please contact after-sales service
33	Battery open circuit or imbalance warning	Please contact after-sales service
34	Battery low temperature warning	Place the vehicle at room temperature and use only after the temperature returns to normal
35	Battery	Let the vehicle stand and use only after internal temperature returns to normal
37	Battery short circuit protection warning	Please contact after-sales service
38	Battery charging overcurrent protection warning	Please disconnect the charger
39	Battery discharge overcurrent protection warning	Please contact after-sales service
40	Battery overcharge warning	The vehicle can operate normally and will recover after the battery level falls down
41	Battery over-discharge warning	Please charge the vehicle
42	Battery communication/verification failure	The speed will be limited to 6 km/h; please contact after-sales service

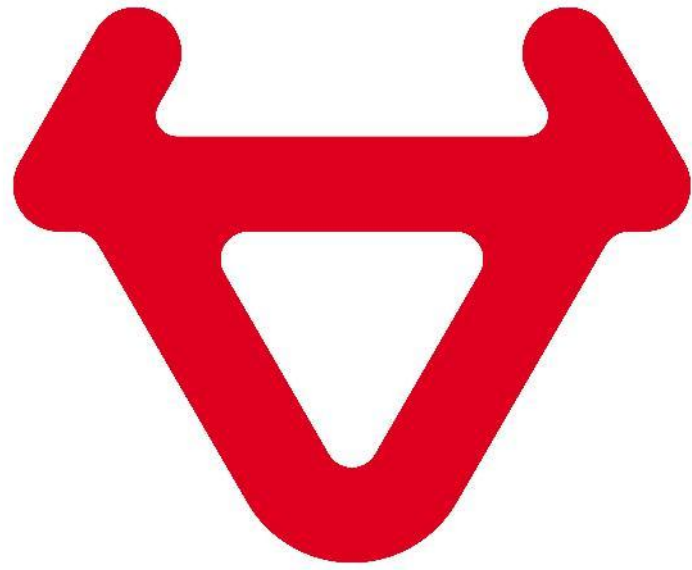

**niu.com**